

## TECHNICAL PARAMETERS Vibration exciter S 51125-IN

Rated peak force Sine <sub>pk</sub> /Random <sub>RMS</sub> <sup>1</sup>	250/150 N
Frequency range	2 - 2000 Hz
Max. displacement Peak-Peak	9 mm
Max. velocity	1.5 m/s
Max. acceleration Sine/Random	2/1.2 g
Suspension stiffness	20 N/mm
Effective moving mass	0.35 kg
Total mass	13 kg
Coupling thread	M12

1) Random force according to ISO 5344:2004

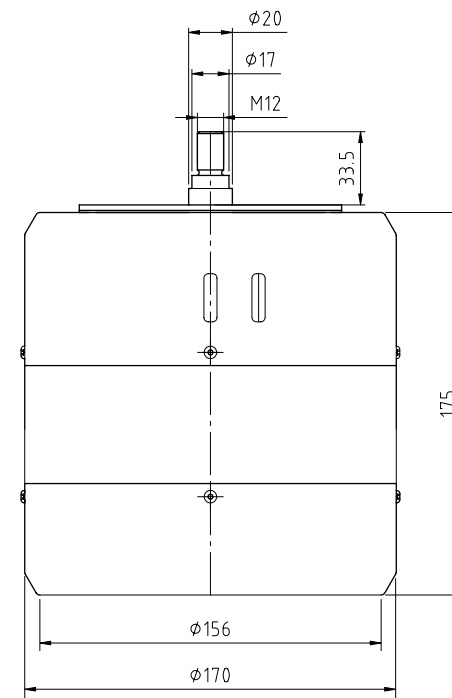

## SCOPE OF DELIVERY, OPTIONS AND FEATURES OF THE SYSTEM

<p><b>Scope of delivery:</b>          Vibration exciter 250 N          Power amplifier 500 VA          Cooling blower          Connection cable (3 m)          Power cable amplifier (1.5 m)          Blower hose ø40 mm (3 m)</p>	<p><b>Options:</b>          Rack for mounting the amplifier          Silencer              for cooling blower (Noise reduction up to 5 dB(A))          Acoustic enclosure              for cooling blower (Noise reduction 15 - 23 dB(A))          Cable extension          Factory acceptance test</p>	<p><b>Features:</b>          Coarse filter unit          High cross-axial stiffness          Light weight construction by using rare earth magnet          Minimum maintenance effort          Made in Germany          Servicehotline</p>
--	---	--

## TECHNICAL PARAMETERS Amplifier BAA 500

Output power <sub>RMS</sub>	500 VA
Frequency range	DC - 20 kHz
Voltage-/Current mode	yes/yes
Voltage <sub>RMS</sub> max	45 V
Current <sub>RMS</sub> max. (below 5 Hz)	11.2 A (5 A)
Signal input voltage <sub>RMS</sub>	< 5 V
Distortion	< 0.1 %
Signal to noise ratio	> 90 dB
Total mass	25 kg
Dimensions (WxHxD)	483 x 90 x 450 mm
Power supply (Standard)	1 ~ / N / PE 230 V ± 5% 50 Hz, CEE 7/7
Recommended fuse protection (Standard)	16 A slow
Max. power consumption at 230 V	0.4 kVA
Interlocks:	Overload, temperature, clipping

### Features:

High Signal to noise ratio of >90 dB

## TECHNICAL PARAMETERS Cooling blower TB 0080

Volume flow rate	max. 80 m <sup>3</sup> /h
Total pressure difference	max. 120 hPa
Power	0.37 kW
Frequency	50 Hz
Hose diameter	40 mm
Hose length (Std.)	3 m
Total mass	10 kg
Dimensions (WxHxD)	246 x 256 x 247 mm
Sound pressure level, max.	max. 53 dB(A)
Power supply (standard)	1 ~ / N / PE 230 V ± 5% 50 Hz, CEE 7/7
Max. current consumption at 230 V	2.7 A

### Options:

Silencer TB 0080-SI (Noise reduction up to 5 dB(A))

Dimensions (LxD): 310 x 65 mm

Mass: 0.2 kg

Acoustic enclosure TB 0080-AE (Noise reduction 15 - 23 dB(A))

Dimensions (WxHxD): 860 x 760 x 650 mm

Mass: 45 kg

Hose length according to customers request (up to 10 m)

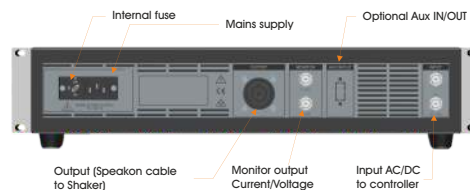

Cooling blower TB 0080



Silencer TB 0080-SI (optional)



Acoustic enclosure TB 0080-AE (optional)