

TECHNICAL PARAMETERS Modal exciter S 50350-M

Rated peak force Sine _{pk} /Random _{RMS}	2700/2000 N
Frequency range	5-3000 Hz
Main resonance frequency	>3000 Hz
Max. displacement Peak-Peak	50.8 mm
Max. velocity Sine/Random	1.5/1.5 m/s
Suspension stiffness	electronically adjusted
Effective moving mass	2.3 kg
Weight	280 kg
Magn. stray field without/with degaussing	<8.5/<1 mT
Coupling thread	M8
Interlocks	Temperature, displacement, cooling air, overcurrent

1) theoretical maximum shock value. Depends on payload, amplifier, shock and shock width

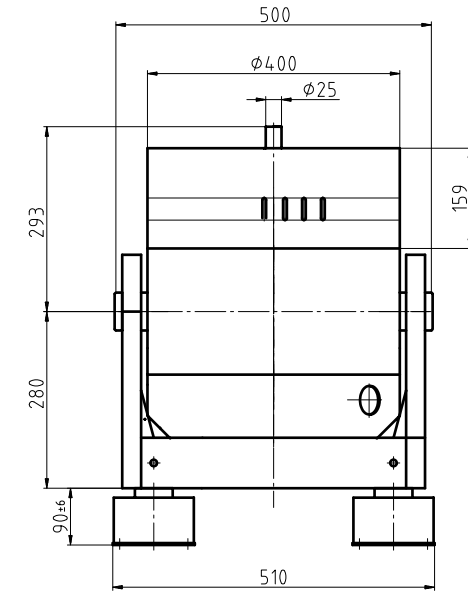

SCOPE OF DELIVERY, OPTIONS AND FEATURES OF THE SYSTEM

<p>Scope of delivery:</p> <ul style="list-style-type: none"> Modal exciter 2.7 kN Swivel frame Power amplifier 4.2 kVA Cooling blower Connection cables (each 5 m) Power cables (5 m) for amplifier (CEE 16 connector) Blower hose ø60 mm (5 m) 	<p>Options:</p> <ul style="list-style-type: none"> Degauss kit to reduce stray magnetic field Squeak&Rattle (Silent operation without blower) Remote control (Software) Silencer for cooling blower (Noise reduction up to 6 dB(A)) Acoustic enclosure for cooling blower (Noise reduction 15 - 23 dB(A)) Cable extension Factory acceptance test 	<p>Features:</p> <ul style="list-style-type: none"> Vibration isolation < 6 Hz Coarse filter unit Fully automatic electronic load compensation Electronic zero point regulation with adjustable stiffness Automatic centering of the armature Integrated mains switch and line filter Integrated field power supply Noise-button Input voltage analyzer Voltage clipping limiter to avoid clipping 3 Sigma Peak current Made in Germany Servicehotline
---	---	---

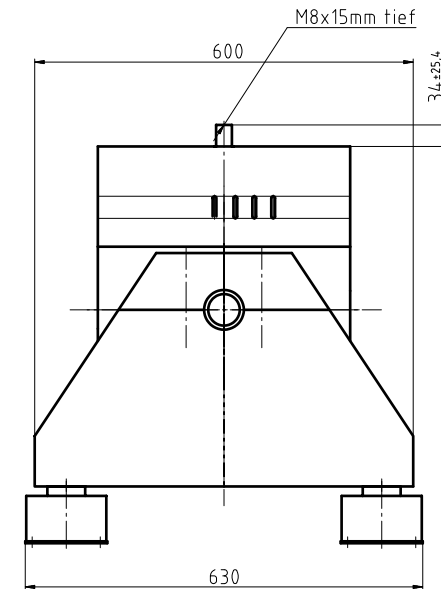

TECHNICAL PARAMETERS Amplifier A 1 01 1 004 T

Output power _{RMS}	4200 VA
Frequency range	DC - 4 kHz
Voltage _{RMS} , max.	105 V
Current _{RMS} , max.	40 A
Load resistance, opt.	2.6 Ohm
Signal input voltage _{RMS} (switchable)	2.5/5/10 V
Distortion	< 0.5 %
Signal to noise ratio	> 90 dB
Field voltage, max.	100 V
Field current, max.	6 A
Weight	225 kg
Dimensions (WxHxD)	600 x 1800 x 800 mm
Power supply (Standard)	3~ / N / PE 400 V±5% 50 Hz, CEE 16
Recommended fuse protection (Standard)	16 A slow
Max. power consumption at 400 V (incl. blower)	6 kVA
Interlocks:	Overload, temperature, clipping and more
Features:	
High Signal to noise ratio of >90 dB	Noise-button
Field supply integrated	Input voltage analyzer
Mains switch and integrated line filter	Voltage clipping limiter to avoid clipping
ESD-monitoring (Protection of the system against damage)	3 Sigma peak current
Field voltage/Field current variable according to customer spec.	Electronic zero-point-regulation (TMC)

TECHNICAL PARAMETERS Cooling blower TB 0310

Volume flow rate	max. 315 m³/h
Total pressure difference	max. 290 mbar
Power	4 kW
Frequency	50 Hz
Hose diameter	60 mm
Hose length (Std.)	5 m
Weight	42 kg
Dimensions (WxHxD)	382 x 384 x 432 mm
Sound pressure level, max.	max. 69 dB(A)
Power supply (standard)	by amplifier rack
Max. power consumption at 400 V	5 kVA
Options:	
Silencer TB 0310-SI (Noise reduction up to 6 dB(A))	
Dimensions (LxD): 308 x 82 mm	
Weight: 0.58 kg	
Acoustic enclosure TB 0310-AE (Noise reduction 15 - 23 dB(A))	
Dimensions (WxHxD): 795 x 841 x 836 mm	
Weight: 55 kg	
Hose length according to customers request (up to 10 m)	



Cooling blower TB 0310



Silencer TB 0310-SI (optional)



Acoustic enclosure TB 0310-AE (optional)