

**TECHNICAL PARAMETERS** Vibration exciter S 59420/AIT-590

Rated peak force Sine <sub>pk</sub> /Random <sub>RMS</sub> <sup>1</sup> /Shock <sub>pk</sub> <sup>2</sup>	200000/168000/600000 N
Frequency range	5 - 2000 Hz
Main resonance frequency	1700 Hz
Max. displacement Sine/Random/Shock (Pk-Pk) <sup>3</sup>	63.5/63.5/76.2 mm
Max. velocity Sine/Random/Shock	2.0/2.0/3.5 m/s
Max. acceleration Sine/Random/Shock	100/75/300 g
Suspension stiffness	250 N/mm
Effective moving mass	125 kg
Max. payload	1300 kg
Total mass	8450 kg
Magnetic stray field <sup>4</sup>	1.5 mT
Armature diameter	590 mm
Required compressed air supply	Min. 700 kPa
Interlocks	Temperature, displacement, water flow rate, differential pressure, overcurrent, compressed air, conductance

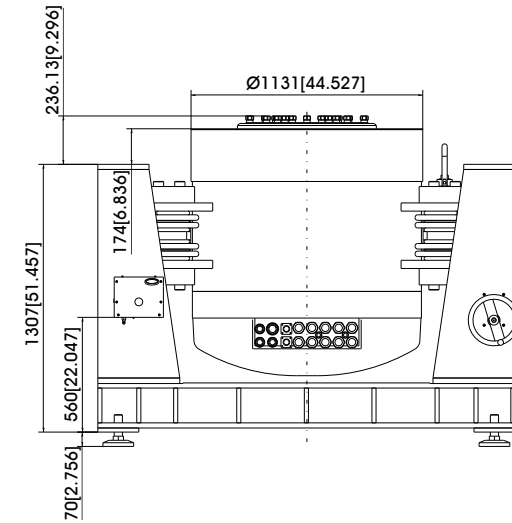

1) Random force according to ISO 5344:2004  
2) Theoretical maximum shock value. Depends on payload, amplifier, shock and shock width  
3) Impact by moving to static mass and frequency is possible  
4) measured at 150 mm above armature inserts

For long-term tests, the load must be reduced to 80 %. Continuous operation at maximum load can cause damage.

**SCOPE OF DELIVERY, OPTIONS AND FEATURES OF THE SYSTEM**

**Scope of delivery:**

- Vibration exciter 200 kN
- Trunnion mount with integrated vibration isolation (AIT)
- Power amplifier 225 kVA
- Cooling unit with integrated hydraulic unit
- Connection cables (each 10 m)
- Water hoses with self-sealing couplings (each 10 m)
- Hydraulic hoses with self-sealing couplings (each 10 m)
- Compressed-air hose NW 7.2 (Standard) (10 m)

**Options:**

- Different hole pattern of armature (different pitch diameter and/or thread inserts) at customers request
- Thermobarrier (-40°C to +140°C)
- Chamber leadthrough
- Climatic chamber support kit
- Remote control (Software)
- ASM-Mode (Auto Shutdown Manager)
- Cable/Hose extension
- Factory acceptance test

**Features:**

- Vibration isolation < 3 Hz (AIT)
- Fully automatic pneumatic load compensation
- Low-friction hydrostatic bearing (Dual Bearing)
- AIT fixable
- Automatic centering of the AIT-System and the armature
- Degauss kit to reduce stray magnetic field
- Shaker-water circuit with overpressure
- Automatic permanent monitoring of conductance
- Integrated mains switch and line filter
- Integrated field power supply
- Energy-saving-mode
- 4 Sigma peak current
- Made in Germany
- Servicehotline

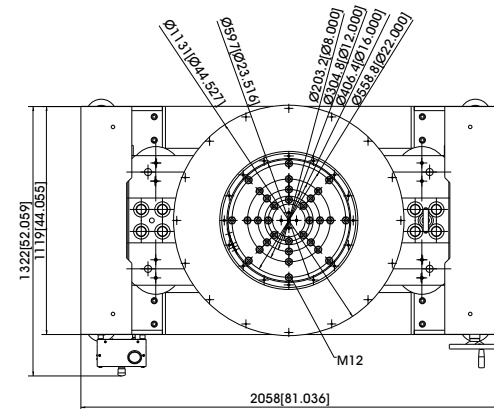

## TECHNICAL PARAMETERS Power Amplifier A 5 85 11 462

Output power <sub>RMS</sub>	225000 VA	<b>Features:</b> Field supply integrated Mains switch and integrated line filter Lo-Field/Hi-Field (Energy-saving mode) Field voltage/Field current variable according to customer spec. 4 Sigma peak current Color-Touchscreen
Frequency range	DC - 5 kHz	
Voltage <sub>RMS</sub> max.	±212 V	
Current <sub>RMS</sub> max.	2200 A	
Signal input voltage	10 V	
Total Harmonic Distortion (at 70A <sub>RMS</sub> , 200 Hz)	< 0.2 %	
Signal to noise ratio	> 80 dB	
Field voltage	240 V	
Field current	355 A	
Total mass	3100 kg	
Dimensions (WxHxD)	2840 x 2200 x 1050 mm	
Power supply (Standard)	3~ / N / PE 400 V±5% 50 Hz	
Recommended fuse protection (Standard)	Direct connection (Terminal block) 450 A slow	
Max. power consumption at 400 V (incl. cooling unit)	290 kVA	
Interlocks:	Overload, Temperature, Displacement, Compressed air, Phase monitoring, Emergency stop, Differential pressure, Water flow rate, Conductance	



## TECHNICAL PARAMETERS Cooling unit C 59430

<b>Environmental conditions:</b>		<b>Features:</b> Closed system --> No pollution and no water loss by evaporation The system works with a higher pressure --> No cavitation interferences at the measuring signal Manometers and flow meters at several places within the circuits Integrated conductance monitoring and demineralisation Fine filter with pollution monitoring Reduction of water consumption at part load by controlling of the process water flow Self-sealing couplings (free from leakage) Optional: Hose length according to customer specs (up to 20 m) Optional: Monitoring of data, warnings and error messages at the PC
Temperature	5 - 30 °C	
Relative humidity	10 - 80 %	
Energy transfer	max. 3 kW	
<b>Process water:</b>		
Temperature	5 - 15 °C	
Volume flow at max. supply temperature	24 m³/h	
Working pressure: supply - static	≤ 10 bar (≤ 1000 kPa)	
Working pressure: dynamic differential pressure	≥ 3 bar (≥ 300 kPa)	
Dissipated heat output	max. 220 kW	
Nominal width of supply pipes	R 1 1/2 IT (40 mm)	
pH value	7 ± 1	
Dimensions of dirt particles	< 25 µm	
Water hardness (total/carbonate)	< 1.4 mmol/l / < 0.9 mmol/l	
Total mass	620 kg	
Dimensions (WxHxD)	800 x 2140 x 1000 mm	

