

**TECHNICAL PARAMETERS** Vibration exciter S 59355/AIT-640

Rated peak force Sine <sub>pk</sub> /Random <sub>RMS</sub> /Shock <sub>pk</sub> <sup>1</sup>	55000/51000/165000 N
Frequency range	5 - 2000 Hz
Main resonance frequency	2000 Hz
Max. displacement Peak-Peak	50.8 mm
Max. velocity Sine/Random/Shock	2.0/2.0/2.5 m/s
Max. acceleration Sine/Random/Shock <sup>1</sup>	70/70/160 g
Suspension stiffness	200 N/mm
Effective moving mass	55.0 kg
Max. weight tested	910 kg
Weight	4550 kg
Magn. stray field std./low degaussing	<2/<1.5 mT
Armature diameter	640 mm
Min. required compressed air supply	600 kPa
Interlocks	Temperature, displacement, cooling air, overcurrent, compressed air

1) theoretical maximum shock value. Depends on payload, amplifier, shock and shock width

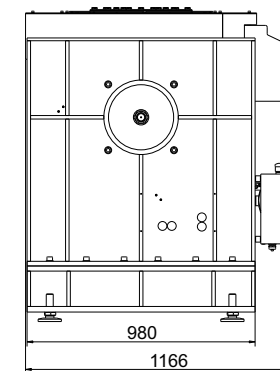
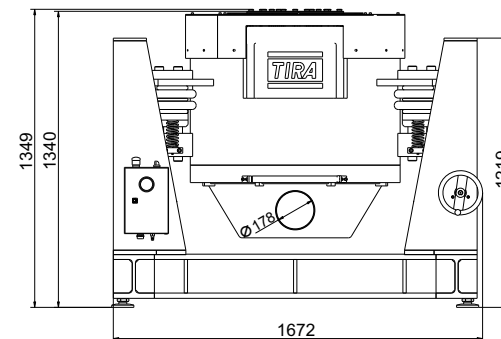

**SCOPE OF DELIVERY, OPTIONS AND FEATURES OF THE SYSTEM**

**Scope of delivery:**  
 Vibration exciter 55 kN  
 Swivel frame  
 with integrated vibration isolation (AIT)  
 Power amplifier 113 kVA  
 Cooling blower  
 Frequency converter  
 Connection cables (each 10 m)  
 Power cables (10 m)  
 for amplifier (direct connection) and cooling blower (CEE 63 connector)  
 Blower hose ø175 mm (5 m)  
 Compressed-air hose NW 7,2 (Standard) (5 m)

**Options:**  
 Different hole pattern of armature (different pitch diameter and/or thread inserts) at customers request  
 Low degaussing kit to further reduce stray magnetic field  
 Airglide-option (Shaker movable on air cushions)  
 Wheels&Rails (incl. 3m rails)  
 Thermobarrier (-40°C to +140°C)  
 Chamber leadthrough  
 Climatic chamber support kit  
 Remote control (Software)  
 Silencer  
 for cooling blower (Noise reduction 9 - 15 dB(A))  
 Acoustic enclosure  
 for cooling blower (Noise reduction 5 - 23 dB(A))  
 Water-cooled acoustic enclosure  
 for cooling blower (Noise reduction 30 dB(A))  
 Cable extension  
 Factory acceptance test

**Features:**  
 AIT-Swivel frame  
 with integrated vibration isolation < 3 Hz  
 Coarse filter unit  
 Fully automatic pneumatic load compensation  
 AIT fixable  
 Automatic centering of the AIT-System and the armature  
 Degauss kit to reduce stray magnetic field  
 Integrated mains switch and line filter  
 Integrated field power supply  
 Energy-saving mode  
 Noise-button  
 Input voltage analyzer  
 Voltage clipping limiter to avoid clipping  
 3 Sigma peak current  
 Made in Germany  
 Servicehotline

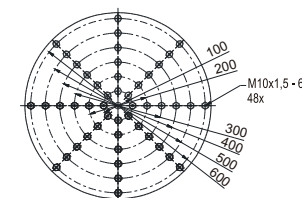

Armature 640 (Standard)

## TECHNICAL PARAMETERS Amplifier A 4 11 3 113

Output power <sub>RMS</sub>	113000 VA
Frequency range	DC - 4 kHz
Voltage <sub>RMS</sub> , max.	150 V
Current <sub>RMS</sub> , max.	750 A
Load resistance, opt.	1 Ohm
Signal input voltage <sub>RMS</sub> (switchable)	2.5/5/10 V
Distortion	< 0.7 %
Signal to noise ratio	> 90 dB
Field voltage, max.	112 V
Field current, max.	100 A
Weight	910 kg
Dimensions (WxHxD)	1200 x 2200 x 800 mm
Power supply (Standard)	3~ / N / PE 400 V±5% 50 Hz
Recommended fuse protection (Standard)	Direct connection (Terminal block)
Max. power consumption at 400 V (incl. blower)	120 A slow
Interlocks:	62 kVA
	Overload, temperature, clipping and more
<b>Features:</b>	
High Signal to noise ratio of >90 dB	Lo-Field/Hi-Field button (Energy-saving mode)
Field supply integrated	Noise-button
Mains switch and integrated line filter	Input voltage analyzer
ESD-monitoring	Voltage clipping limiter to avoid clipping
(Protection of the system against damage)	3 Sigma peak current
Field voltage/Field current variable according to customer spec.	

## TECHNICAL PARAMETERS Cooling blower TB 7/FU/20

Volume flow rate*	3000-3300 m³/h
Total pressure difference*	9.5 - 10.2 kPa
Power	20 kW
Frequency	105 Hz
Hose diameter	175 mm
Hose length (Std.)	5 m
Weight	157 kg
Dimensions (WxHxD)	625 x 700 x 575 mm
Sound pressure level, max.	105 dB(A)
<b>Frequency converter (moveable):</b>	
Weight	150 kg
Dimensions (WxHxD)	600 x 1400 x 400 mm
Power supply (variable)	3~ / PE 400 V±5% 50 Hz
	CEE 63
Recommended fuse protection (Standard)	50 A slow
Max. power consumption at 400 V	27 kVA
<b>Options:</b>	
Silencer TB 7/FU-SI (Noise reduction 9 - 15 dB(A))	
Dimensions (LxD):	1120 x 280 mm
Weight:	9.2 kg
Acoustic enclosure TB 7/FU-AE (Noise reduction 5 - 23 dB(A))	
Dimensions (WxHxD):	1130 x 1630 x 1630 mm
Weight:	103 kg
Water-cooled acoustic enclosure WWT (Noise reduction 30 dB(A))	
Dimensions (WxHxD):	1500 x 2080 x 1200 mm
Weight:	800 kg
Hose length according to customers request (up to 10 m)	

\*During operation at vibration exciter

